

DRAWING FOR QUOTATION PURPOSES ONLY. NOT TO BE WORKED TO.

ISSUE: A  
BY: AG  
RN: N/A  
DATE: 02/06/2010

DESCRIPTION OF LAST CHANGE

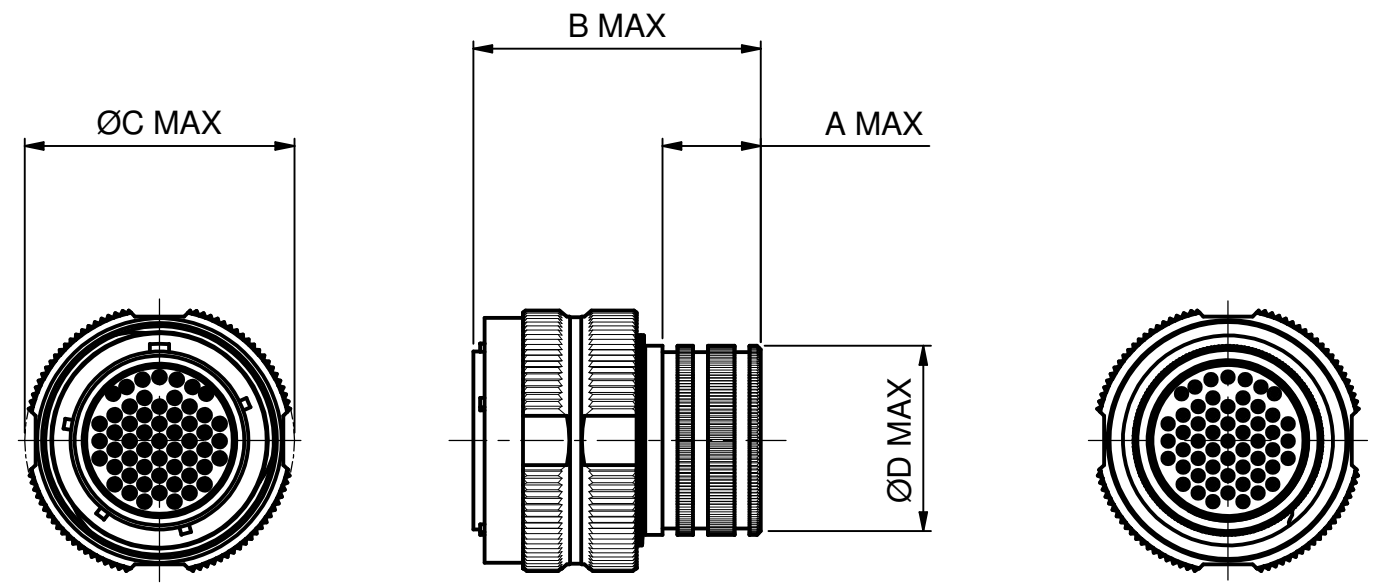

EXAMPLE PART NUMBER: **ABAC 37 W 17 35 S N**

PRODUCT SERIES \_\_\_\_\_

SHELL STYLE \_\_\_\_\_

FINISH (TABLE 2) \_\_\_\_\_

SHELL SIZE (TABLE 1) \_\_\_\_\_

INSERT ARRANGEMENT \_\_\_\_\_

CONTACT TYPE \_\_\_\_\_  
P = PIN CONTACTS  
S = SOCKET CONTACTS

ORIENTATION \_\_\_\_\_

\*CONSULT FACTORY FOR CUSTOM REQUIREMENTS

SHELL SIZE	A MAX	B MAX	ØC MAX	ØD MAX
9	13.00	38.00	21.00	12.10
11	13.00	38.00	23.70	15.10
13	13.00	38.00	29.30	18.10
15	13.00	38.00	31.30	22.10
17	13.00	38.00	35.67	25.10
19	13.00	38.00	38.40	28.10
21	13.00	38.00	41.67	31.10
23	13.00	38.00	44.90	34.10
25	13.00	38.00	47.97	37.10

REF	FINISH DESCRIPTION
QB	ZINC COBALT BLACK PASSIVATE
W	OLIVE DRAB CADMIUM
Q	ZINC COBALT GREEN PASSIVATE
F	ELECTROLESS NICKEL



MODIFICATIONS MUST BE CARRIED OUT USING CAD SYSTEM

CHARACTERISTIC	SYM	CHARACTERISTIC	SYM
STRAIGHTNESS	—	ANGULARITY	∠
FLATNESS	▭	RUN OUT	↗
ROUNDNESS	○	POSITION	⊕
CYLINDRICITY	⊘	CONCENTRICITY	◎
PROFILE OF A LINE	⌒	SYMMETRY	≡
PROFILE OF A SURFACE	⌒	M.M.C.	Ⓜ
PARALLELISM	//	SQUARENESS	⊥

FOR EXPLANATION OF DIMENSIONS, TOLERANCES, NOTES, ETC. SEE BS308

MATERIAL:  
**N/A**

TOLERANCES UNLESS OTHERWISE STATED  
ALL DECIMAL PLACES ± 0.1  
HOLE DIAMETERS ± 0.05  
ANGULAR ± 2°

DRAWN **AG**  
DATE 25/02/2010  
CHKD **PL**

√ = CRITICAL CHARACTERISTIC    ◊ = SIGNIFICANT CHARACTERISTIC (SEE AB-W07-03-01 FOR DESCRIPTION)

Do not scale this drawing    Variations start at 001

 <b>AB CONNECTORS LTD.</b> A TT GROUP COMPANY	TITLE: <b>OVERMOULD VERSION OF 38999 PLUG WITH RFI SHIELDING</b>	FINISH: <b>SEE PED 021</b>				
THIS DRAWING MAY ONLY BE ALTERED IF THE PART REMAINS INTERCHANGEABLE. IF NOT, A NEW DRAWING NUMBER MUST BE TAKEN.	PRODUCT DRAWING NUMBER <b>ABAC.CDS.0005</b>	<table border="1" style="width:100%; border-collapse: collapse; font-size: 8px;"> <tr> <th>FINISH CODE</th> <th>VARN</th> </tr> <tr> <td style="text-align: center;">SEE PED 021</td> <td></td> </tr> </table>	FINISH CODE	VARN	SEE PED 021	
FINISH CODE	VARN					
SEE PED 021						